

# Modeling of Power Efficiency Sensor Network

Duncan Kilungu, Machakos University. Department of Electrical & Electronic Engineering.

**Abstract**—Wireless Sensor Nodes forms an ad-hoc network that is widely used in remote deployment applications and has a unique characteristic of low battery-operated devices, and hence energy saving of sensor nodes is a major design issue. Life span of any given sensor network can be prolonged if the energy minimization is taken care of under all ISO layer. Most scholar have demonstrated that energy consumption in support of node remain an unanswered.

To analyze the energy spent during the node communication it's the major goal of this paper. How long can a node be sustained during the time when the information is been shared. The model study investigate only two modulation techniques, BPSK and QAM if adopted in modulating the signal during transmission.

The transmitter power is modeled using the relationship between SNR and cut-off rate and the Circuit power is modeled considering the power consumption used in a WSN node

**Index Terms**—Wireless sensor network on power efficiency modulation.

## Introduction

The concept of wireless sensor networks is based on a simple equation: Sensing + CPU + Radio =Thousands of potential applications. However, actually combining sensors, radios, and CPU's into an effective wireless sensor network, it r requires a detailed understanding of the both capabilities and limitations of each of the underlying hardware components. Understanding of modern networking technologies and distributed systems theory plays a major role in sensor network.. Each individual node must be designed to provide the set of primitives necessary to synthesize the interconnected web that will emerge as they are deployed, while meeting strict requirements of size, cost and power consumption. A core

challenge is to map the overall system requirements down to individual device capabilities, requirements and actions. The development of low-cost, low-power, a multifunctional sensor has received increasing attention from various industries. Sensor nodes or motes in WSNs are small sized and are capable of sensing, gathering and processing data while communicating with other connected nodes in the network, via radio frequency (RF) channel. WSN term can be broadly sensed as devices range from laptops, PDAs or mobile phones to very tiny and simple sensing devices. At present, most available wireless sensor devices are considerably constrained in terms of computational power, memory, efficiency and communication capabilities due to economic and technology reasons.

What's why most of the research on WSNs has concentrated on the design of energy and computationally efficient algorithms and protocols, and the application domain has been confined to simple data-oriented monitoring and reporting applications. WSNs nodes are battery powered which are deployed to perform a specific task for a long period of time, even years. If WSNs nodes are more powerful or mains-powered devices in the vicinity, it is beneficial to utilize their computation and communication resources for complex algorithms and as gateways to other networks. New network architectures with heterogeneous devices and expected advances in technology are eliminating current limitations and expanding the spectrum of possible applications for WSNs

This paper is organized in five section part-1 gives the introduction; 2 Architecture and modeling of WSN architecture; 3 Literature review; 4 Implementation and 5 Analysis and the result

## 2. Architecture, Standards & Modeling Wireless Sensor Node Architecture:

The basic block diagram of a wireless sensor node is presented in. It is made up four basic components: a sensing unit, a processing unit, a transceiver unit and a power unit. [6] There can be application dependent additional components such as a location finding system, a power generator and a mobilize

### 2.1 Sensing Unit:

Sensing units are usually composed of two subunits: sensors and analog to digital converters (ADCs). Sensor is a device which is used to translate physical phenomena to electrical signals. Sensors can be classified as either analog or digital devices. There exists a variety of sensors that measure environmental parameters such as temperature, light intensity, sound, magnetic fields, image, etc. The analog signals produced by the sensors based on the observed phenomenon are converted to digital signals by the ADC and then fed into the processing unit.

### 2.2 Processing Unit:

The processing unit mainly provides intelligence to the sensor node. The processing unit consists of a micro-processor, which is responsible for control of the sensors, execution of communication protocols and signal processing algorithms on the gathered sensor data. Commonly used microprocessors are Intel's Strong ARM microprocessor, Atmel's AVR microcontroller and Texas Instruments' MP430 microprocessor. For example, the processing unit of a smart dust mote prototype is a 4 MHz Atmel AVR8535 micro-controller with 8 KB instruction flash memory, 512 bytes RAM and 512 bytes EEPROM. TinyOS operating system is used on this processor, which has 3500 bytes OS code space and 4500 bytes available code space. The processing unit of  $\mu$ AMPS wireless sensor node prototype has a 59–206 MHz SA-1110 micro-processor. In general, four main processor states can be identified in a microprocessor: *off*, *sleep*, *idle* and *active*. In sleep mode, the CPU and most internal peripherals are turned on, and can only be activated by an external event (interrupt). In idle mode, the CPU is still inactive, but other peripherals are active.

### 2.3 Transceiver Unit:

The radio enables wireless communication with neighboring nodes and the outside world. It

consists of a short range radio which usually has single channel at low data rate and operates at unlicensed bands of 868-870 MHz (Europe), 902-928 MHz (USA) or near 2.4 GHz (global ISM band). For example, the TR1000 family from RF Monolithic works in the 800–900 MHz range can dynamically change its transmission power up to 1.4mW and transmit up to 115.2 Kbps. The Chipcon's CC2420 is included in the MICAZ mote that was built to comply with the IEEE 802.15.4 standard for low data rate and low cost wireless personal area networks. There are several factors that affect the power consumption characteristics of a radio, which includes the type of modulation scheme used, data rate, transmit power and the operational duty cycle. At transmitted power levels of -10dBm and below, a majority of the transmit mode power is dissipated in the circuitry and not radiated from the antenna. However, at high transmit levels (over 0dBm) the active current drawn by the transmitter is high. The transmit power levels for sensor node applications are roughly in the range of -10 to +3 dBm. Similar to microcontrollers, transceivers can operate in *Transmit*, *Receive*, *Idle* and *Sleep* modes.

An important observation in the case of most radios is that, operating in *idle* mode results in significantly high power consumption, almost equal to the power consumed in the *Receive* mode. Thus, it is important to completely shut down the radio rather than set it in the *idle* mode when it is not transmitting or receiving due to the high power consumed. Another influencing factor is that, as the radio's operating mode changes, the transient activity in the radio electronics causes a significant amount of power dissipation. The sleep mode is a very important energy saving feature in WSNs.

### 2.4 Battery:

The battery supplies power to the complete sensor node. It plays a vital role in determining sensor node lifetime. The amount of power drawn from a battery should be carefully monitored. Sensor nodes are generally small, light and cheap, the size of the battery is limited. AA batteries normally store 2.2 to 2.5 Ah at 1.5 V. However, these numbers vary depending on the technology utilized. For example, Zinc-air-based batteries have higher capacity in Joules/cm<sup>3</sup> than lithium batteries. Alkaline batteries have the smallest capacity, normally around 1200 J/cm<sup>3</sup>. Furthermore, sensors must have a lifetime of months to years, since battery replacement is not

an option for networks with thousands of physically embedded nodes. This causes energy consumption to be the most important factor in determining sensor node lifetime.

**IEEE 802.15.4 Standard**

**2.2.1 Introduction**

The introduction of IEEE 802.15.4 low rate wireless personal area network (LR-WPAN) standard has been implemented for three reasons: the need for low-cost, low-power and short-range communication. Thus it suits for Wireless Sensor Network applications where a large no of tiny sensors having low power, low range and low bandwidth are deployed in an ad hoc manner for the purpose of Automation, Tracking and Surveillance in terrain regions. The standard defines the channel access mechanism, acknowledged frame delivery, network association and disassociation. The standard supports two Direct Sequence Spread Spectrum (DSSS) PHY layers operating in Industrial, Scientific, Medicine (ISM) frequency bands. A low-band PHY operates in the 868 MHz (megahertz) or 915 MHz frequency band and has a raw data rate of 20 kbps or 40 kbps, respectively. A high-band PHY operating in the 2.4 GHz band specifies a data rate of 250 kbps and has nearly worldwide availability. The 2.4 GHz frequency band has the most potential for large-scale WSN applications, since the high radio data rate reduces frame transmission time and usually also the energy per transmitted and received bit of data.

This standard now enjoys extensive silicon support, primarily in the 2.4GHz band. On top of this PHY and MAC layer standard, several proprietary and standards-based sensor network systems emerged. The one with the most vendor and end-product support is the Zigbee standard.

**2.2.2 IEEE 802.15.4 PHY Layer**

PHY layer provides an interface between the MAC layer and the physical radio channel. [6]It provides two services, accessed through two service access points (SAPs). These are the PHY data service and the PHY management service.

**a) Modulations Schemes and Operational Frequencies**

The IEEE 802.15.4 standard specifies the multiple PHYs for 868, 915 and 2400 MHz three frequency bands, they use different modulation schemes and different spread spectrum methods to transmit data in different data rates with different chip rates.

There are total 37 channels with different bandwidth specified in the standard, which includes one channel in 868 MHz frequency band and 10 channels in 915 MHz frequency band and 16 channels in 2.4 GHz frequency band.

The 868/915 MHz PHY uses a simple DSSS approach in which each transmitted bit is represented by a 15-chip maximum length sequence. Binary data is encoded by multiplying each m-sequence by +1 or -1 and the resulting chip sequence is modulated onto the carrier using binary phase shift keying[5] (BPSK). Differential data encoding is used prior to modulation to allow low-complexity differential coherent reception.

The 2.4 GHz PHY uses a 16-ary quasi-orthogonal modulation technique based on DSSS methods. Binary data is grouped into 4-bit symbols, and each symbol specifies one of sixteen nearly orthogonal 32-chip, pseudo-random noise (PN) sequences for transmission. PN sequences for successive data symbols are concatenated, and the aggregate chip sequence is modulated onto the carrier using, offset-quadrature phase shift keying (OQPSK)

PHY	Frequency	Spreading Parameters		Data Parameters		
	Band (MHz)	Chip Rate (kchip/s)	Modulation	Bit Rate (kb/s)	Symbol Rate (Ksymbol/s)	Symbols
868/915	868-868.6	300	BPSK	20	20	Binary
	902-928	600	BPSK	40	40	Binary
2450	2400-	2000	O-QPSK	250	62.5	16-ary
	2483.5					Orthogonal

**Table: 2 Physical layer specification**

**The IEEE PHY layer functions:**

The IEEE 802.15.4 physical layer has been responsible for the following functions:

**Activation and deactivation of the radio transceiver**

Turn the radio transceiver into one of the three states, i.e. transmitting, receiving or off (sleeping) according to the request from MAC sub layer. The turnaround time from transmitting to receiving, or vice versa, is less than 12 symbol periods

**b) Energy Detection (ED) within the current channel**

It is an estimate of the received signal power within the bandwidth of an IEEE 802.15.4 channel. No attempt is made to identify or decode signals on the channel in this procedure. The energy detection time is equal to 8 symbol periods. The result from energy detection can be

used by a network layer as part of a channel selection algorithm, or for the purpose of clear channel assessment (CCA).

**c) Link Quality Indication (LQI) for received packets**

Link quality indication measurement is performed for each received packet. The Physical layer uses receiver energy detection (ED), a signal-to-noise ratio, or a combination of these to measure the strength and/or quality of a link from which a packet is received. However, the use of LQI result by the network or application layers is not specified in the standard.

**d) Clear Channel Assessment (CCA) for CSMA-CA**

The PHY layer is required to perform CCA using energy detection, carrier sense, or a combination of these two. In energy detection mode, the medium is considered busy if any energy above a predefined energy threshold is detected. In carrier sense mode, the medium is considered busy if a signal with the modulation and spreading characteristics of IEEE 802.15.4 is detected. In the combined mode, both conditions aforementioned need to be met in order to conclude that the medium is busy.

**e) Channel frequency selection**

Wireless links under 802.15.4 can operate in 27 different channels (but a specific network can choose to support part of the channels). Hence the PHY layer should be able to tune its transceiver into a certain channel upon receiving the request from MAC sub layer.

**Data transmission and reception**

The 2.4 GHz PHY employs a 16-ary quasi-orthogonal modulation technique, in which each four information bits are mapped into a 32-chip pseudo-random noise (PN) sequence. The PN sequences for successive data symbols are then concatenated and modulated onto the carrier using offset quadrature phase shift keying (O-QPSK). The 868/915 MHz PHY employs direct sequence spread spectrum (DSSS) with binary phase shift keying (BPSK) used for chip modulation and differential encoding used for data symbol encoding. Each data symbol is mapped into a 15-chip PN sequence and the concatenated PN sequences are then modulated onto the carrier using BPSK with raised cosine pulse shaping.

**IEEE 802.15.4 MAC Sub layer**

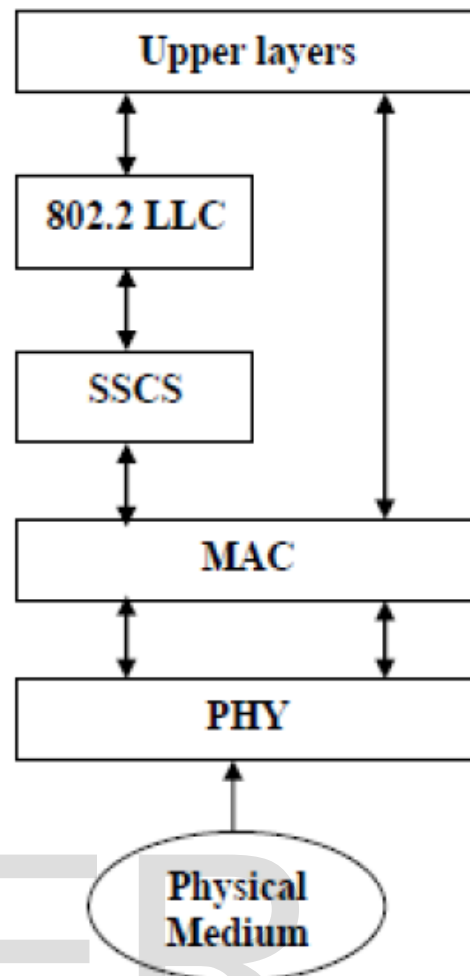

**Fig 2.2 MAC Sub layer**

The IEEE 802.15.4 MAC sub layer provides an interface between the service specific convergence sub layer (SSCS) and the PHY layer. Like the PHY layer, the MAC sub layer also provides two services, namely the MAC data service and the MAC management service. The MAC sub layer of 802.15.4 defines how the medium should be accessed by devices participating in a WPAN. A MAC sub layer provides access to

**3: LITERATURE SURVEY**

Recently, various research efforts were focused on the power consumption issues of WSNs. Several authors [1, 2, 3, 4, and 5] presented the problem and proposed solutions for it using several simulation techniques. They suggested the use of specific protocols and algorithm to cope with the power consumption problem in PHY and MAC layers.

**3.1 Energy Optimization for Reliable Point-to-Point Communication in Energy-Constrained Networks.**

Researchers have used many modulation and coding techniques and have employed them in various channels. F. Costa and H. Ochiai Used a specific modulation MQAM and based on the relations between capacity (cut-off rate) and the SNR for a given MQAM constellation, the optimum transmission scheme that

may result in minimum energy was derived for a given distance between the communicating wireless nodes through numerical analysis.

### 3.2 A Comparison of Modulations for Energy Optimization in Wireless Sensor Network Links.

They extended the above study by considering three different modulation types frequently employed in wireless communications; [2] **MQAM, MPSK, and MFSK**, and derive an energy minimization scheme for point-to-point wireless communications. Among these, MFSK was chosen as the preferable choice for WSN because of its constant PAR ratio of the transmit signal and low complexity.

### 3.3 Energy-constrained modulation optimization for coded systems.

In both the transmitter and receiver blocks only the RF component was considered for calculating the SNR. Goldsmith analyzed the best modulation technique that can be implemented when error control codes are used. To minimize the total energy, the time in "ON" state and Constellation size are optimized. MQAM and MFSK were used and trellis-coded and convolutional coded systems were used for studying. [4][1] They discussed both un-coded and coded techniques to compare the efficiency in power reduction and concluded that for short range applications un-coded MFSK is better than the coded compatriot and un-coded MQAM is bore bandwidth efficient than un-coded MFSK.

### 3.4 Energy efficient modulation design for wireless sensor networks

Gulliver considered the power spent on circuitry and MAC protocol for energy spent per information bit. They employed Direct Digital Modulation architecture (DDM) [4] and used symbol synchronization algorithm. Non-coherent FSK was used as the scheme because of its flexibility and support for adaptive modulation.

**3.5 An Energy-Efficient source coding and modulation schemes for Wireless Sensor Networks** Andrews used DS-CDMA system using OOK modulation. 2 types of coding techniques were implemented and compared. Minimum Energy coding and Modified Minimum Energy coding were used and MME along with OOK was concluded the better technique for DS-CDMA systems as it reduces Interference and transmitted power.

## 4: IMPLEMENTATION

Wireless Sensor Networks typically consists of a large number of sensor nodes distributed over a certain region. The radio frequency (RF) transceiver, A/D and D/A converters, baseband processors, and other application interfaces into one device which is called as sensor node. These sensor nodes are characterized by their low power, small size and cheap price. Thus, in

many scenarios, the wireless nodes must operate without battery replacement for many years. Consequently, minimizing the energy consumption is a very important [4] design consideration, and energy-efficient transmission schemes must be used for the data transfer in sensor networks. They actually transform the data into electric signals, which are then processed to reveal some of the characteristics about the phenomena located in the area around the sensors.

We investigate the energy consumption associated with both the transmitting path and the receiving path: namely the total energy required to convey a given number of bits to the receiver for reliable detection.[4] Thus, minimizing the energy consumption along both the transmitting path and the receiving path at the same time is more appropriate than minimizing them separately. [2]The energy saving issue is significant since in a wireless node, the battery energy is finite and hence a node can only transmit a finite number of bits. The maximum number of bits that can be sent is defined by "The total battery energy divided by the required energy per bit". Research has been mostly in the area of transmission schemes to minimize the transmission energy per bit. This is reasonable in the traditional wireless link where the transmission distance is large ( $\geq 100$  m), so that the transmission energy is dominant in the total energy consumption. However, recent ad-hoc networks are densely designed and the average distance between nodes is usually below 10 m. In such cases the circuit energy consumption dominates the transmission energy in the total energy consumption. Hence the overall energy consumption including both transmission and circuit energy consumption needs to be considered [1]

### Scenario

We study a single link of a WSN. The problem can be stated as:

The transmitter node needs to transmit L information bits to the receiver in a maximum allowed time limit of T seconds. We consider that the average bit rate is the same as the one in the IEEE 802.15.4 standard channels operating in the 2.4 GHz ISM band, i.e. 250 Kbps.

### Circuit Model

For estimating the power spent in the transmission of information bits, besides considering the energy spent by the transmitted signal, [4]we consider the power consumed by the RF circuitry of both transmitter and receiver. Some typical power consumptions of RF circuits used in present practical implementations or promised for near future implementations are used in our analysis. We analyze RF circuits with power consumptions of 0.1, 1, 50, 100, 150, 200, 250 and 300 mW. The node is considered to have 3 states of operation.

- (i) ON

(ii) SLEEP

(iii) TRANSIENT.

The *on* state is used for the transmission of information. The *sleep* state is used for saving energy and the *transient* state is a temporary one between the *sleep* and *on* states. Since a node is inactive in the *sleep* state, the other two states are considered.

The Energy spent per information bit is given as,

$$E_{infBit} = (P_{on} * T_{on} + P_{tr} * T_{tr}) / L$$

Where,  $E_{infBit}$  – Energy per information bit.

$P_{on}$  – Power in the “ON” state.

$P_{tr}$  – represent power in the “TRANSIENT” state.

$T_{on}$  – represent time in the “ON” state.

$T_{tr}$  – represent time in the “TRANSIENT” state.

**Circuit Power calculation:**

The power while the circuit is in the *on* state is composed of the transmitted signal power ( $P_{Tx}$ ), the power of the circuit ( $P_C$ ), and the power of the power amplifier ( $P_{PA}$ ). In Summary,

**System model**

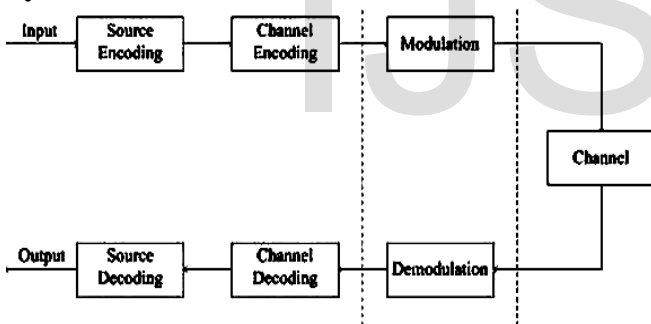

Figure: 4 Block diagram [4]

$$P_{on} = P_{Tx} + P_{PA} + P_C \tag{4.1}$$

Where,

$P_{Tx}$  – Power of the signal transmitted.

$P_C$  – Power of the circuit.

$P_{PA}$  – Power of the amplifier.

Power consumption of the power amplifier ( $P_{PA}$ ) is given by

$$P_{PA} = \alpha * P_{Tx}$$

Where,

$$\alpha = (\xi / \eta) - 1,$$

Where,

$\xi$  - peak-to-average power ratio (PAR).

$\eta$  - The drain efficiency of the PA.

Substituting the above parameters,

$$E_{infBit} = ((1 + \alpha) P_{Tx} * T_{on} + P_C * T_{on} + P_{tr} * T_{tr}) / L$$

**Transmitted Power calculation:**

The SNR measured at the receiver can be expressed as, --- (4.1)

$$SNR = (P_{Rx} * T_S) / N_0 * N_f.$$

Where,

$N_f$  - The receiver noise figure.

$N_0$  - The power spectral density of the noise per dimension.

$P_{Rx}$  can be written as,

$$P_{Rx} = (SNR * N_0 * N_f) / T_S.$$

The Transmitted signal’s power is calculated using the following relation,

$$P_{Tx} = P_{Rx} * G_d = P_{Rx} * G_I * (d^k) * M_I$$

Where,

$P_{Rx}$  – Power of the Received signal.

$M_I$  – the link margin

$G_d$  - Power gain factor.

$G_I$  - The gain factor.

The variable  $T_{on}$  can be related to the information rate  $R$ , given in information bits per symbol and modelled using cut-off rate as

$$R = L / (T_{on} / T_S) \tag{4.2}$$

The numerator is the total number of information bits to be transmitted and the denominator is the total number of symbols used to transmit these bits. Equivalently, we have

$$T_{on} = (L * T_S) / R \tag{4.3}$$

Substituting all the above values we get,

$$E_{infBit} = ((1 + \alpha) * (SNR) * N_0 * N_f * G_d) / R + (P_C * M) / (2 * R * B) + (P_{tr} * T_{tr}) / L \tag{4.10}$$

This equation has to be optimized and for that the node's standard values are assumed for calculation.

**Simulation & Observation Standard Values**

The Standard values are assumed from IEEE 802.15.4 WPAN networks.

Frequency	2.4GHz
Bandwidth	250KHz
Data	25Kbps
Modulation	BPSK/QAM
Distance	1-30m
Total Time(T)	100ms
Circuit power Pc	0.1,100, 300m W

**Table: System parameter**

The Energy spent is simulated in comparison to the distance and the consumption is observed and analyzed. The equation is given as:

$$E_{infBit} = ((1 + \alpha) * (SNR) * N_0 * N_f * G_d) / R (P_c * M) / (2 * R * B) + (P_{tr} * T_{tr}) / L$$

**Result and analysis**

**i. BPSK in AWGN Channel**

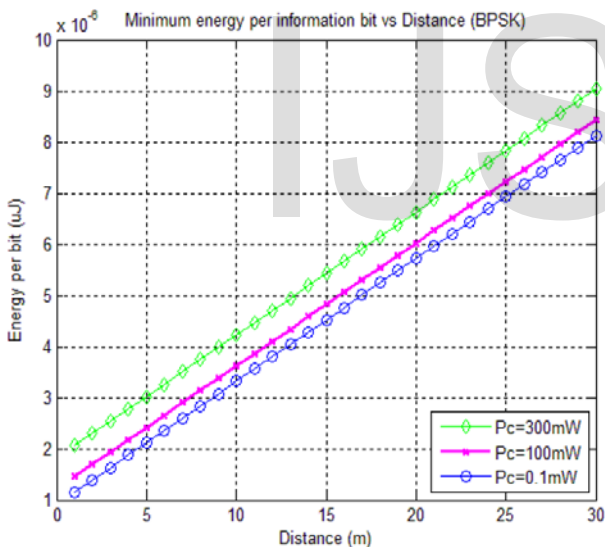

**Fig: 5.1 BPSK in AWGN channel**

The graph shows the Energy spent per bit values plotted with respect to the distance for various circuit powers modeled using AWGN channel for BPSK. It is evident that circuit power Pc=0.1mW has the minimum energy spent in comparison with the other two power levels

**ii. BPSK in Rayleigh Channel**

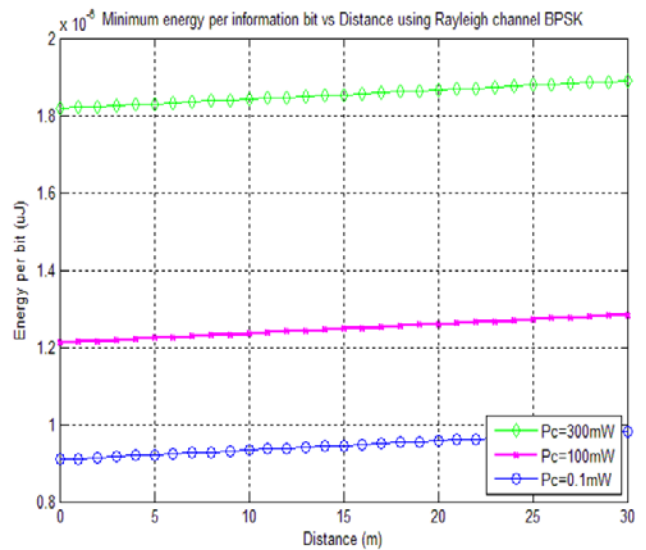
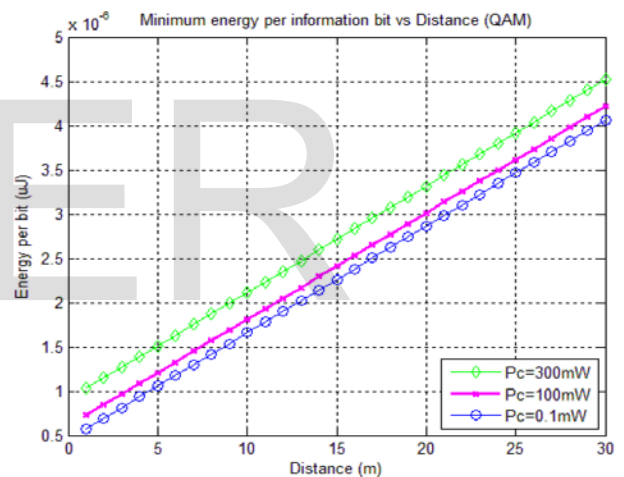

**Fig: 5.2 BPSK in Rayleigh Channel**

The energy spent is modeled in Rayleigh channel and it is reduced to a max value of 1μJ for

Pc=0.1mW when compared to fig 5.1.

**iii. QAM in AWGN Channel**



**Fig: 5.3 QAM in AWGN Channel**

In this case QAM modulation is considered and the same comparison is modeled for AWGN channel using QAM. The energy consumption value for Pc=0.1mW increases from 0.5μJ to 4μJ.

**iv. QAM in Rayleigh Channel**

## REFERENCES

- [1] F. Costa and H. Ochiari, "Energy Optimization for Reliable Point-to-Point Communication in Energy-Constrained Networks," in *Proceedings of IEEE 71st Vehicular Technology Conference 2010 (VTC 2010-Spring)*, pp. 1–5, 2010.
- [2] F. Costa and H. Ochiari, "A Comparison of Modulations for energy optimization for wireless sensor network links," in *Proceedings of IEEE 71st Vehicular Technology Conference 2010 (GLOBECOM 2010)*, pp. 1– 5, 2010.
- [3] S. Cui, A. J. Goldsmith, and A. Bahai, "Energy-constrained modulation optimization," *IEEE Trans. on Wireless Commun.* vol. 4, no. 5, pp. 2349– 2360, Sept. 2005.
- [4] X. Liang, W. Li, W.A. Gulliver, "Energy efficient modulation design for wireless sensor networks" in *Proc. of IEEE PACRIM'07*, Aug. 2007.
- [5] J. Kim, J. G. Andrews, "An Energy-Efficient source coding and modulation schemes for Wireless Sensor Networks", *Signal Processing Advances in Wireless Communications, 2005 IEEE 6th Workshop on Digital Object Identifier*.
- [6] "Protocols and Architecture for Wireless Sensor Networks", Holger Kahl, Andreas Willig.

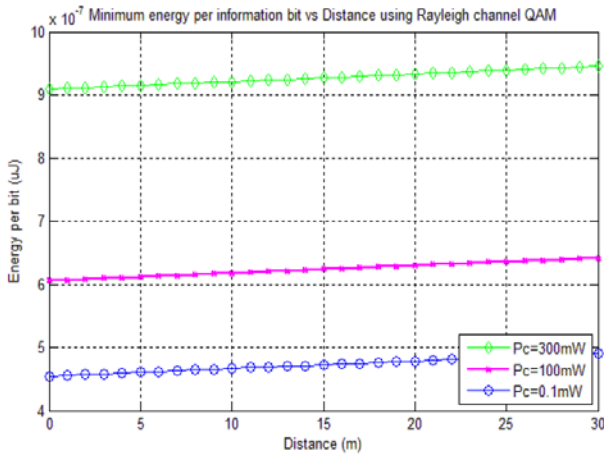

Fig: 5. 4 QAM in Rayleigh Channel

The energy spent value for  $P_c=0.1\text{mW}$  is reduced to around  $4.9\mu\text{J}$ . This inference provides conclusive evidence that QAM is comparatively energy efficient than BPSK in both the channels.

## CONCLUSION & FUTURE WORK

In this proposal, the Energy-optimization equation was simulated and analyzed for both AWGN and Rayleigh channel. Some Practical aspects were considered in this work, i.e. different RF circuit power consumptions and 802.15.4 standard specifications of bandwidth limit. From the Simulations it is observed that QAM is more energy efficient in both the channels because the energy consumption is comparatively lower than BPSK. The current design was considered for a single link between 2 nodes in a wireless model. The analysis assumed many factors to be ideal. This project observation can be used as guidelines for analyzing various modulations schemes. Also this methodology can be enhanced further by considering a small n- node network of sensors.